

# **Appendix D1**

## **On-Road Mobile Source Inventory Development Overview**

**Base Year 2017 Emissions Inventory**

**(Washington, DC-MD-VA 2015 Ozone  
NAAQS Nonattainment Area)**



# DEVELOPMENT OF OZONE ON-ROAD MOBILE EMISSIONS INVENTORIES

Prepared for the 2015 Ozone National Ambient Air Quality Standards  
2017 Base Year for the Washington, DC-MD-VA Non-Attainment Area

December 2019



National Capital Region  
**Transportation Planning Board**

## **DEVELOPMENT OF OZONE ON-ROAD MOBILE EMISSIONS INVENTORIES**

December 2019

Prepared for the Metropolitan Washington Air Quality Committee (MWAQC)

### **ABOUT THE TPB**

The National Capital Region Transportation Planning Board (TPB) is the federally designated metropolitan planning organization (MPO) for metropolitan Washington. It is responsible for developing and carrying out a continuing, cooperative, and comprehensive transportation planning process in the metropolitan area. Members of the TPB include representatives of the transportation agencies of the states of Maryland and Virginia and the District of Columbia, 24 local governments, the Washington Metropolitan Area Transit Authority, the Maryland and Virginia General Assemblies, and nonvoting members from the Metropolitan Washington Airports Authority and federal agencies. The TPB is staffed by the Department of Transportation Planning at the Metropolitan Washington Council of Governments (COG).

### **CREDITS**

Kanti Srikanth, Director, Department of Transportation Planning

Jinchul Park

Daniel Son

Anant Choudhary

Jane Posey

Dusan Vuksan

Feng Xie

### **ACCOMMODATIONS POLICY**

Alternative formats of this document are available upon request. Visit [www.mwcog.org/accommodations](http://www.mwcog.org/accommodations) or call (202) 962-3300 or (202) 962-3213 (TDD).

### **TITLE VI NONDISCRIMINATION POLICY**

The Metropolitan Washington Council of Governments (COG) fully complies with Title VI of the Civil Rights Act of 1964 and related statutes and regulations prohibiting discrimination in all programs and activities. For more information, to file a Title VI related complaint, or to obtain information in another language, visit [www.mwcog.org/nondiscrimination](http://www.mwcog.org/nondiscrimination) or call (202) 962-3300.

El Consejo de Gobiernos del Área Metropolitana de Washington (COG) cumple con el Título VI de la Ley sobre los Derechos Civiles de 1964 y otras leyes y reglamentos en todos sus programas y actividades. Para obtener más información, someter un pleito relacionado al Título VI, u obtener información en otro idioma, visite [www.mwcog.org/nondiscrimination](http://www.mwcog.org/nondiscrimination) o llame al (202) 962-3300.

# TABLE OF CONTENTS

<b>1. INTRODUCTION</b>	<b>1</b>
<b>2. BACKGROUND</b>	<b>1</b>
<b>3. OVERVIEW OF METHODS AND PLANNING ASSUMPTIONS</b>	<b>1</b>
<b>4. TRAVEL DEMAND MODEL AND INPUTS</b>	<b>4</b>
<b>5. MOVES MODEL INPUTS</b>	<b>5</b>
5.1 Post Processor	5
5.2 VMT/VHT Fractions	7
5.3 Average Speed	8
5.4 Road Type	11
5.5 Age Distribution	12
5.6 Fuel Formulation	12
5.7 Meteorology Data	12
5.8 Ramp Fraction	12
5.9 Road Type Distribution	12
5.10 Source Type (Vehicle) Population	13
5.11 Inspection/Maintenance (I/M) Programs & Hoteling	14
5.12 Source Type (Vehicle) Population	14
<b>6. RESULTS</b>	<b>15</b>
<b>ATTACHMENT A</b>	<b>17</b>
<b>ATTACHMENT B</b>	<b>21</b>
<b>ATTACHMENT C</b>	<b>25</b>

## TABLES

TABLE 1 TRAVEL-RELATED ASSUMPTIONS/METHODS USED IN THE INVENTORIES	2
TABLE 2 NON-TRAVEL RELATED ASSUMPTIONS AND METHODS USED IN THE INVENTORIES	2
TABLE 3 2017 HOUSEHOLD AND EMPLOYMENT DATA	4
TABLE 4 2017 AVERAGE WEEKDAY VEHICLE MILES TRAVELED	5
TABLE 5 AVERAGE WEEKDAY VHT DISTRIBUTION FOR REFUSE TRUCKS	10
TABLE 6 VHT DISTRIBUTION OF SCHOOL BUSES (6:00 AM – 6:00 PM)	11
TABLE 7 VHT DISTRIBUTION OF TRANSIT BUSES	11
TABLE 8 2017 VEHICLE POPULATION	14
TABLE 9 ON-ROAD MOBILE EMISSIONS INVENTORIES (IN SHORT TONS/DAY)	15
TABLE 10 ON-ROAD MOBILE EMISSIONS INVENTORIES BY JURISDICTION (IN SHORT TONS/DAY)	16
TABLE 11 REFUELING EMISSIONS FOR 2015 OZONE NAAQS (IN SHORT TONS/DAY)	16

## FIGURES

FIGURE 1 WASHINGTON DC-MD-VA OZONE NON-ATTAINMENT AREA MAP	3
FIGURE 2 POST-PROCESSING OF TRAVEL DEMAND RESULTS	7
FIGURE 3 VMT CALCULATION PROCESS	8
FIGURE 4 ROAD TYPE DISTRIBUTION DEVELOPMENT PROCESS	13

## 1. INTRODUCTION

This report documents the development of the 2017 base-year on-road emissions inventories for the 2015 Ozone National Ambient Air Quality Standards (NAAQS) for the Washington, DC-MD-VA non-attainment area. The inventories were developed by National Capital Region Transportation Planning Board (TPB) staff at the request of the Metropolitan Washington Air Quality Committee (MWAQC). The on-road inventories will be combined with emissions estimates developed for other sources to formulate a complete base-year inventory of ground-level ozone precursors in the region. This report summarizes the planning assumptions and technical methods supporting the on-road inventory development and presents results at the jurisdiction level. The inventory addresses three pollutants: Carbon Monoxide (CO), Nitrogen Oxides (NO<sub>x</sub>), and Volatile Organic Compounds (VOC).

## 2. BACKGROUND

Effective August 3, 2018 the Environmental Protection Agency (EPA) designated the Metropolitan Washington, DC-MD-VA region as a “marginal” non-attainment area for the 2015 Ozone NAAQS (70 parts per billion). Under a “marginal” designation, it is not necessary to develop an Attainment State Implementation Plan (SIP), but there is a requirement to develop a base-year inventory. The base-year inventory must include emissions from all sectors: point, area, on-road mobile, and non-road. It must be submitted to the EPA by August 3, 2020.

## 3. OVERVIEW OF METHODS AND PLANNING ASSUMPTIONS

Mobile emissions inventories were developed using the regional travel demand model and the EPA MOTO Vehicle Emissions Simulator (MOVES) model. Several sequential steps were undertaken in the process. First, TPB’s adopted travel demand model was used to estimate vehicle miles of travel (VMT) at the network link level of analysis. The modeled VMT outputs were developed at the network link level by vehicle type and by four time-of-day periods. Next, a post processor was used to further refine link-level VMT and link speeds into vehicle-hours of travel (VHT) by facility type, hourly periods and speed “bins.” Finally, several data preparation steps were undertaken before the MOVES mobile emissions model was executed on a jurisdictional basis in order to compute mobile emissions. An overview of the travel model, post processor, and MOVES data preparation steps is presented below.

The TPB staff developed 2017 travel-related data specifically for this effort. The key planning assumptions and methods are listed in Table 1. The modeling methods include the TPB’s currently adopted travel demand model, Version 2.3.75,<sup>1</sup> and the EPA MOVES2014b emissions model. The land activity projections used in the travel demand modeling are based on the Round 9.1 Cooperative Forecasts.

---

<sup>1</sup> Ngo Ray et al., “User’s Guide for the COG/TPB Travel Demand Forecasting Model, Version 2.3.75. Volume 1 of 2: Main Report and Appendix A (Flowcharts)” (Washington, D.C.: Metropolitan Washington Council of Governments, National Capital Region Transportation Planning Board, December 5, 2018), [https://www.mwcog.org/assets/1/6/mwcog\\_tpb\\_travel\\_model\\_v2.3.75\\_user\\_guide\\_v4\\_append\\_a.pdf](https://www.mwcog.org/assets/1/6/mwcog_tpb_travel_model_v2.3.75_user_guide_v4_append_a.pdf).

**Table 1 Travel-Related Assumptions/Methods Used in the Inventories**

Land Activity:	COG Round 9.1 Cooperative Forecasts
Project Inputs:	Visualize 2045 Long Range Transportation Plan
Travel Demand Model:	Version 2.3.75
Mobile Emissions Model:	MOVES2014b
Vehicle Registration Data:	2016 Vehicle Registration Inventories with corrected DC data

The non-travel related inputs to the MOVES2014b model, relating to meteorology, inspection and maintenance programs, and fuel formulation and supply, were provided by state air agencies in coordination with COG’s Department of Environmental Programs (DEP). DEP staff provided modeling assumptions and guidance in a May 18, 2019 email (Attachment A). The non-travel related assumptions and methods underlying the ozone emissions inventories are listed in Table 2.

**Table 2 Non-Travel Related Assumptions and Methods Used in the Inventories**

Inspection & Maintenance Programs:	Year-specific programs/MOVES2014b format
Fuel Programs:	Year-specific programs/MOVES2014b format
Meteorology:	July 2017 data from Dulles Airport

The Washington, D.C region Ozone Non-Attainment Area includes the following jurisdictions: Washington, D.C., Montgomery County, Prince George’s County, Frederick County, Charles County, Calvert County, the City of Alexandria, Arlington County, Fairfax County, Loudoun County, and Prince William County. The cities and towns within each jurisdiction are also included. The Ozone Non-Attainment Area and the area associated with travel modeling are shown in Figure 1.



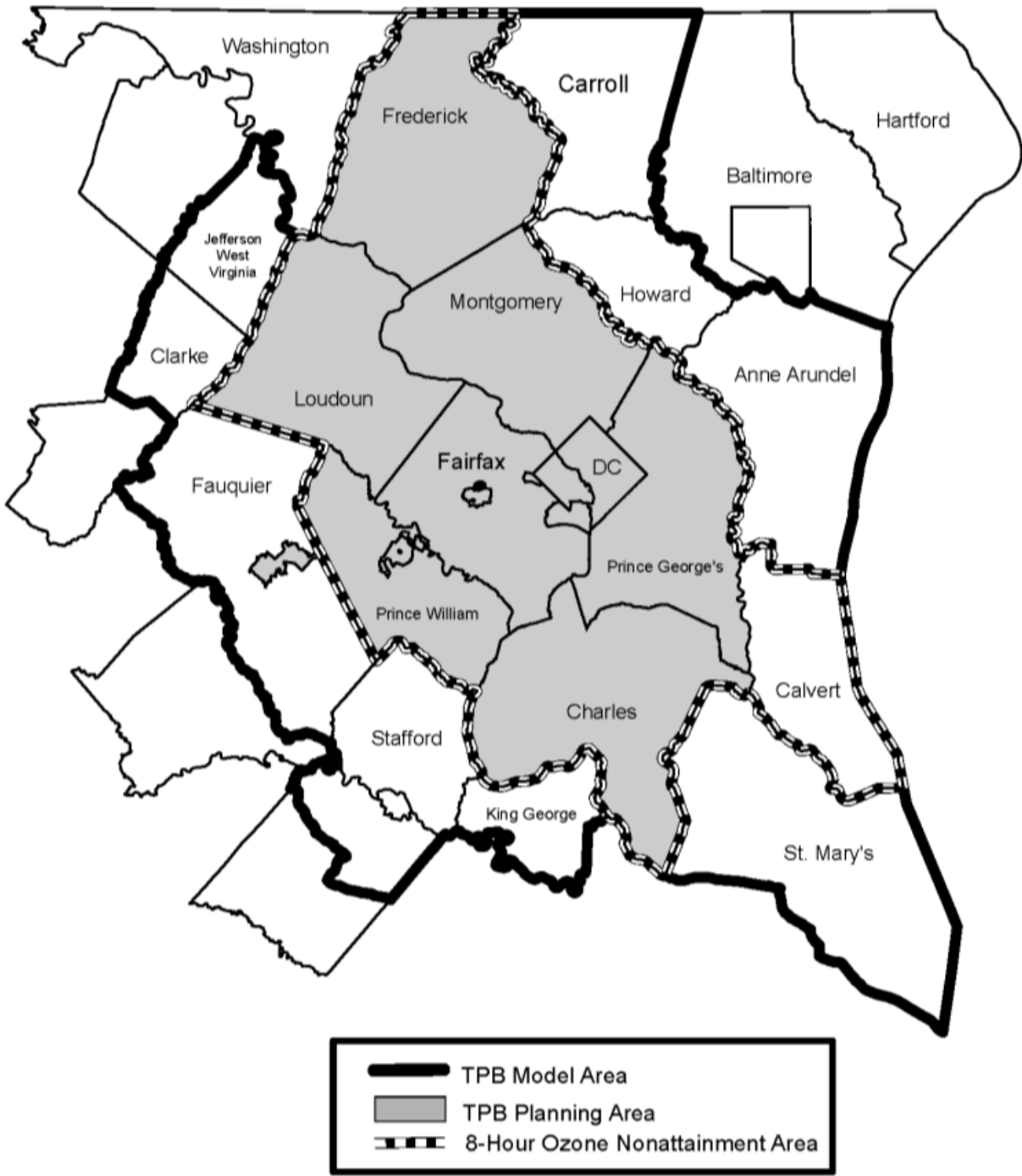

Figure 1 Washington DC-MD-VA Ozone Non-Attainment Area Map

## 4. TRAVEL DEMAND MODEL AND INPUTS

The Version 2.3.75 Travel Model is an aggregate, trip-based, four-step travel demand model that operates on a 3,722 Transportation Analysis Zone (TAZ) system. The Ver. 2.3 Model was calibrated to year-2007 conditions (using the 2007/08 Household Travel Survey and several on-board transit surveys).<sup>2</sup> The model was validated twice – first to year-2010 conditions <sup>3</sup> and second to year-2014 conditions.<sup>4</sup> The Version 2.3.75 Model is documented in a recent User’s Guide.<sup>5</sup>

The COG Round 9.1 Cooperative Forecasts are projections of households, population, and employment (by type), prepared at the TAZ level. Household and employment summaries by jurisdiction for the 2017 analysis year are provided in Table 3.

**Table 3 2017 Household and Employment Data**

Jurisdiction	Households	Employment
District of Columbia	305,963	817,462
Montgomery Co., MD	381,359	529,480
Prince George's Co., MD	326,394	342,747
Arlington Co., VA	107,070	212,552
City of Alexandria, VA	72,980	107,792
Fairfax Co., VA	423,156	708,912
Loudoun Co., VA	127,819	178,354
Prince William Co., VA	165,884	182,622
Frederick Co., MD	93,284	114,013
Charles Co., MD	56,331	46,759
Calvert Co., MD	32,697	35,120
<b>Total</b>	<b>2,092,937</b>	<b>3,275,813</b>

Source: MWCOG Round 9.1 Cooperative Forecasts. Employment includes an adjustment to ensure that a consistent employment definition is used throughout the modeled area.<sup>6</sup>

The travel demand model produces a wide array of outputs including zone-level trip matrices (which are then aggregated to the jurisdiction level) and vehicle volumes on the highway and transit networks. Modeled VMT is the most critical output of the travel model for the purpose of estimating on-road emissions. The jurisdiction-level VMT results estimated by the Version 2.3.75 Travel Demand Model for this exercise are listed in Table 4. The VMT estimates shown reflect on-network

2 Ronald Milone et al., “Calibration Report for the TPB Travel Forecasting Model, Version 2.3, on the 3,722-Zone Area System,” Final Report (Washington, D.C.: Metropolitan Washington Council of Governments, National Capital Region Transportation Planning Board, January 20, 2012), <https://www.mwcog.org/transportation/data-and-tools/modeling/model-documentation/>.

3 Ronald Milone to Files, “2010 Validation of the Version 2.3 Travel Demand Model,” Memorandum, June 30, 2013, <https://www.mwcog.org/transportation/data-and-tools/modeling/model-documentation/>.

4 Feng Xie to Dusan Vuksan and Mark Moran, “Year-2014 Validation of TPB’s Version 2.3 Travel Demand Model,” Memorandum, March 12, 2019.

5 Ray Ngo et al., “User’s Guide for the COG/TPB Travel Demand Forecasting Model, Version 2.3.75: Volume 1 of 2: Main Report and Appendix A (Flowcharts)” (Washington, D.C.: Metropolitan Washington Council of Governments, National Capital Region Transportation Planning Board, December 5, 2018), <https://www.mwcog.org/transportation/data-and-tools/modeling/model-documentation/>.

6 Hamid Humeida and Ray Ngo to Mark S. Moran et al., “Developing Land Use Input Files for the Version 2.3 Travel Model Using Round 9.1 Cooperative Forecasts and the CTPP-Based Employment Adjustment Factors (Update and Corrections by Ray Ngo, 10/25/18),” Memorandum, October 25, 2018.

travel only and do not include local road VMT, since the networks used in the travel model do not explicitly include local roads (only freeways, arterials, and collectors).

**Table 4 2017 Average Weekday Vehicle Miles Traveled**

Jurisdiction	2017
District of Columbia	8,374,418
Montgomery Co., MD	22,242,072
Prince George's Co., MD	23,725,570
Arlington Co., VA	3,971,417
City of Alexandria, VA	2,090,483
Fairfax Co., VA	27,597,367
Loudoun Co., VA	7,913,326
Prince William Co., VA	10,179,697
Frederick Co., MD	8,992,214
Charles Co., MD	3,126,043
Calvert Co., MD	1,774,569
<b>Total</b>	<b>119,987,176</b>

*Source: 2017 model run using Version 2.3.75 Model, 9.1 Cooperative Forecasts, and Visualize 2045 networks and inputs*

## 5. MOVES MODEL INPUTS

The MOVES model was executed on a year-specific basis, for each jurisdiction in the Ozone Non-Attainment Area. As such, jurisdiction-level databases (or Excel files) are prepared in a format that is consistent with prescribed specifications in the software documentation. Some inputs are prepared as parameters that are defined in MOVES-related scripting. TPB staff currently executes the MOVES2014b model in the “inventory” mode, indicating that the MOVES model is used to calculate actual mobile emissions inventories in short tons per day for each jurisdiction in the non-attainment area (rather than used to calculate rates).

When EPA released initial versions of the MOVES emissions model, a regional task force was formed to provide guidance on MOVES-related inputs that would be acceptable to regional stakeholders. Staff from both transportation and environmental agencies served on the task force. During 18 monthly meetings, between August 2009 and January 2010, the task force agreed to an approach for developing emissions inventories using MOVES. A summary table of the approach is included as Attachment B.

### 5.1 Post Processor

A post processor is used to reformat network link-level outputs from the travel model into MOVES compatible format. The post processor is used to create vehicle hours of travel (VHT) and vehicle miles traveled (VMT) distributions by jurisdiction. The jurisdictional VMT distributions are distinguished by three vehicle types (passenger vehicles, commercial vehicles, and trucks), and two

facility types (freeways and arterials), and the jurisdictional VHT distributions are further distinguished by hour of day and 14 speed groups or “bins.”

The post processor aggregates six travel markets from the travel demand model outputs into three vehicle types as follows:

- Passenger Vehicles = SOV + HOV2 + HOV3 (or more) + Airport Passenger Trips;
- Commercial Vehicles = Commercial Vehicles;
- Heavy Duty Vehicles = Trucks;

Six facility types are grouped into two as follows:

- Freeway = freeway + expressway + freeway ramp; and
- Arterial = major arterial + minor arterial + collector.

The post processor is executed four times for each analysis year: one run for each of the three vehicle types and another for all vehicle types combined. The post processor yields jurisdictional VMT and hourly VHT distributions by MOBILE’s 14 speed bins and two facility types.<sup>7</sup> Figure 2 illustrates the post-processing of travel demand outputs. The post processor also includes provisions to add local VMT to the on-network VMT developed by the travel model, so that the full universe of travel is accounted for.

---

<sup>7</sup> Prior to the EPA MOVES model, the EPA MOBILE model was used.

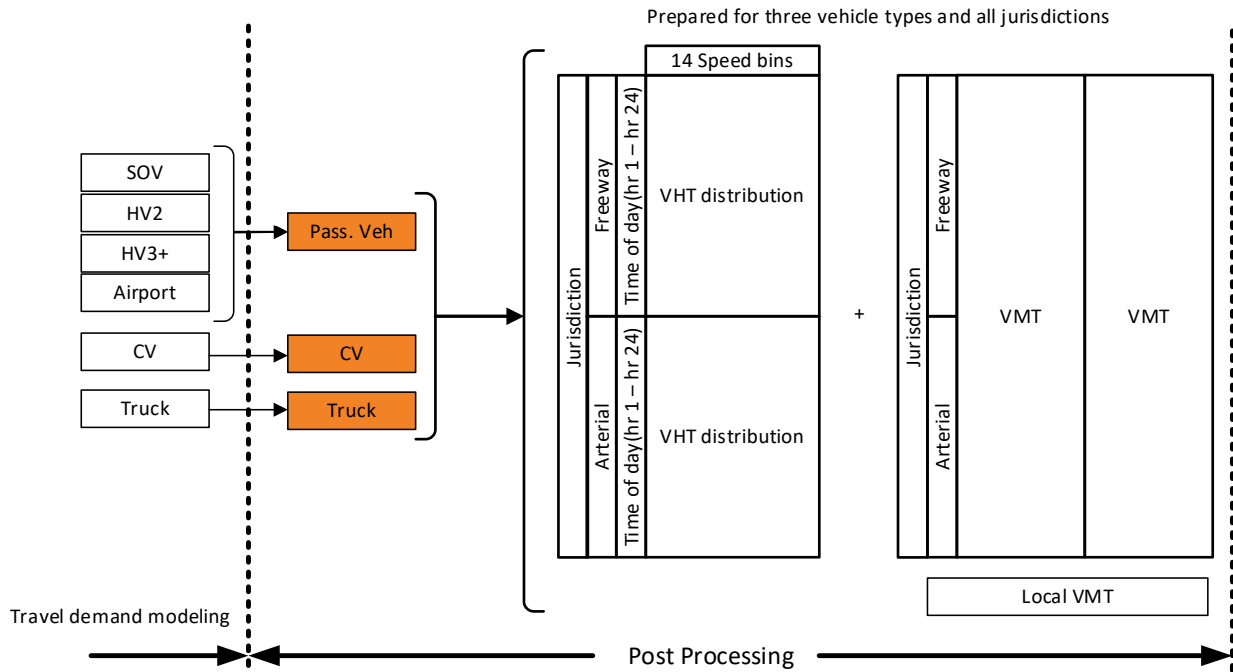

Pass. Veh = passenger vehicle  
 CV = commercial vehicle  
 Truck = heavy duty vehicle

Freeway = freeway, expressway & freeway ramp  
 Arterial = major/minor arterials, collectors & local roads

**Figure 2 Post-Processing of Travel Demand Results**

## 5.2 VMT/VHT Fractions

The MOVES2014b model requires annual VMT by five Highway Performance Monitoring System (HPMS) vehicle types:

- Motorcycle (sourceTypeID = 10);
- Light-duty vehicle (sourceTypeID = 25);
- Buses (sourceTypeID = 40);
- Single-unit trucks (sourceTypeID = 50); and
- Combination trucks (sourceTypeID = 60).

Average annual weekday VMT estimates include on-network data from the travel demand model outputs as well as local road VMT estimates, which are added in exogenously. Auto access VMT for transit riders, estimated from post processing, is added to the VMT of Light Duty Vehicles (sourceTypeID = 25). Modeled VMT is divided into three vehicle types: passenger vehicles, commercial vehicles, and heavy-duty vehicles. Local road VMT is developed by using a combination of observed and simulated data in the post-processing shown in Figure 3.

The local road VMT shares are added to VMT from the travel model to produce total VMT. The resulting total VMT of the three vehicle types is then classified by five MOVES vehicle types using

observed jurisdictional Highway Performance Monitoring System (HPMS) VMT percentages. Figure 3 illustrates the process of developing VMT for five HPMS vehicle types.

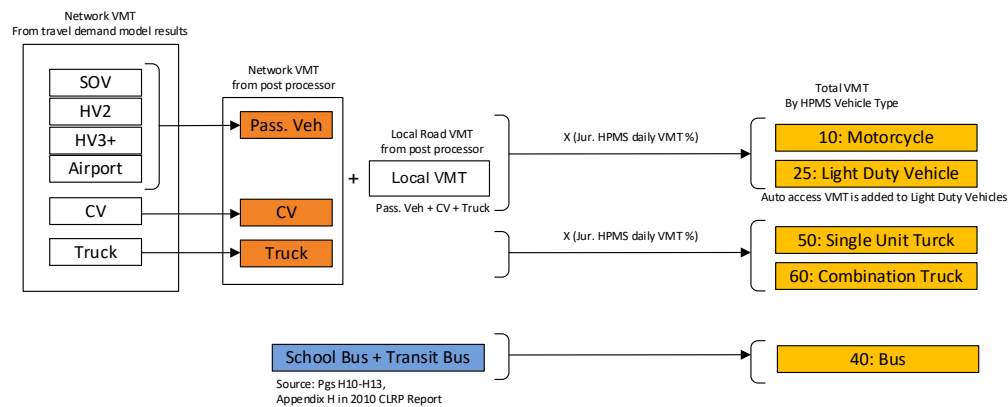

**Figure 3 VMT Calculation Process**

An EPA converter, [AAD VMT Calculator HPMS.XLS](#), is used to convert daily VMT to the required annual VMT necessary for MOVES. The converter uses annual average weekday VMT (AADVMT) at the HPMS level to calculate type of day (i.e., weekday or weekend day), monthly and yearly VMT in terms of HPMS and/or MOVES source types. It generates the HPMSVTypeYear, monthVMTFraction, and dayVMTFraction tables from AADVMT and monthly/weekend-day adjustment factors.

### 5.3 Average Speed

MOVES requires speed distributions by vehicle type and time period. Vehicle Hours of Travel (VHT) distributions are selected as a suitable proxy for average speed distribution. COG/TPB's regional travel demand model outputs are first processed to derive VHT distributions for six vehicle categories:

- Single Occupancy Vehicles (SOV);
- High Occupancy Vehicles 2 (HOV2);
- High Occupancy Vehicles 3+ (HOV3 or more);
- Commercial Vehicles;
- Trucks; and
- Airport Passenger Trips.

Through post-processing, six VHT distributions are developed for three vehicle types, MOBILE's 14 speed bins, hour of the day, and two facility types (i.e., freeways and arterials); and later reclassified into MOVES' 16 speed bins, hour of the day, day of the week (i.e., weekdays and weekend days), and four facility types. Six vehicle types from the travel demand model are reclassified into three vehicle types as follows:

- Passenger Vehicles = SOV + HOV2 + HOV3 (or more) + Airport Passenger Trips;
- Commercial Vehicles = Commercial Vehicles ;
- Heavy Duty Vehicles = Trucks.

MOVES requires: (1) 16 speed bins from 2.5 mph to 75 mph in increments of 5 mph; and (2) four road types, which are a combination of two facility types (i.e., restricted and unrestricted) and two environmental settings (i.e., urban and rural settings). The restricted facilities include freeways, expressways and freeway ramps, while the unrestricted facilities include major/minor arterials, collectors, and local roads. The following assumptions are used to develop average speed distributions fulfilling the MOVES requirements stated above:

1. VHT Distribution to Restricted Facilities:

a. All vehicle types:

- Weekday VHT Distribution:
  - All Day: Hourly distribution for all vehicles
- Weekend VHT Distribution:
  - 11:00 am – 7:00 pm: Distribution across the 13 MOVES vehicle type categories reflecting the 3:00 pm hour on a weekday
  - 7:01 pm – 10:59 am: Distribution across the 13 MOVES vehicle type categories reflecting the 12:00 am hour on a weekday

2. VHT Distribution to Unrestricted Facilities:

a. All vehicle types exclusive of refuse trucks, school buses and transit buses:

- Weekday VHT Distribution:
  - All Day: Hourly distribution for all vehicles
- Weekend VHT Distribution:
  - 11:00 am – 7:00 pm: Distribution reflecting the 3:00 pm hour on a weekday
  - 7:01 pm – 10:59 am: Distribution reflecting the 12:00 am hour on a weekday

b. Refuse trucks: Refuse trucks operate on a 3-phase cycle: Phase 1 is the period of driving from the dispatch garage to trash collection sites; Phase 2 is the period of the actual trash/recycle collection; Phase 3 is the period of driving back to transfer stations. Using local data from Fairfax County, VA, the average speed of Phases 1 and 3 is assumed to be in the range of 22.5-27.5 miles per hour (i.e., MOVES Speed Bin 6), and the average speed of Phase 2 is assumed to be in the range of 2.5-7.5 miles per hour (i.e., MOVES Speed Bin 2). Based on the above assumptions the refuse truck vehicle type VHT distributions are as follows:

- Weekday VHT Distribution (see Table 5):
  - 5:00 am–5:00 pm (Trash Collection): VHT hourly distributions according to Phases 1, 2 and 3.
  - 5:01 pm–5:00 am (On Road Phase): VHT hourly distribution consists of Phase 2.
- Weekend VHT Distribution:
  - All Day: VHT distribution made up of Phase 1 and Phase 3 (on road phases)

- c. School buses:
  - Weekday VHT Distribution:
    - 6:00 am – 6:00 pm: VHT distribution (see Table 6)
    - 6:00 pm – 6:00 am: VHT distribution of heavy duty vehicles
  - Weekend VHT Distribution:
    - 11:00 am–7:00 pm: VHT Distribution of heavy duty vehicles at 3:00 pm on a weekday
    - 7:00 pm – 11:00 am: VHT Distribution of heavy duty vehicles at 12:00 am on a weekday
- d. Transit buses:
  - Weekday VHT Distributions (see Table 7):
    - 6:00 – 9:00 am: Per WMATA’s bus speed distribution of the AM peak period
    - 9:00 am–3:00 pm: Per WMATA’s bus speed distribution of the off-peak period
    - 3:00 - 6:00 pm: Per WMATA’s bus speed distribution of the PM peak period
    - 6:00pm-6:00 am: Per WMATA’s bus speed distribution of the off-peak period
  - Weekend VHT Distribution (see Table 7):
    - All Day: Per WMATA’s bus speed distribution of the off-peak period.

**Table 5 Average Weekday VHT Distribution for Refuse Trucks**

Speed Bins	Speed Range	5:00 AM - 5:00 PM	5:01 PM - 4:59 AM
1	speed < 2.5mph	0.00%	0.00%
2	2.5mph <= speed < 7.5mph	62.65%	0.00%
3	7.5mph <= speed < 12.5mph	0.00%	0.00%
4	12.5mph <= speed < 17.5mph	0.00%	0.00%
5	17.5mph <= speed < 22.5mph	0.00%	0.00%
6	22.5mph <= speed < 27.5mph	37.35%	100.00%
7	27.5mph <= speed < 32.5mph	0.00%	0.00%
8	32.5mph <= speed < 37.5mph	0.00%	0.00%
9	37.5mph <= speed < 42.5mph	0.00%	0.00%
10	42.5mph <= speed < 47.5mph	0.00%	0.00%
11	47.5mph <= speed < 52.5mph	0.00%	0.00%
12	52.5mph <= speed < 57.5mph	0.00%	0.00%
13	57.5mph <= speed < 62.5mph	0.00%	0.00%
14	62.5mph <= speed < 67.5mph	0.00%	0.00%
15	67.5mph <= speed < 72.5mph	0.00%	0.00%
16	72.5mph <= speed	0.00%	0.00%

Source: Fairfax County, VA <sup>8</sup>

<sup>8</sup> Sivasailam, Daivamani, et al., “Vehicle Hours of Travel (VHT) Distribution for Refuse Truck,” (MOVES Task Force Meeting, Washington, D.C.: Metropolitan Washington Council of Governments, National Capital Region Transportation Planning Board, September 21, 2010)  
 V:\MOVES\Memos\_MOVES\_Task\_Force\2010.09.21\3.Item 3a.pdf



**Table 6 VHT Distribution of School Buses (6:00 am – 6:00 pm)**

avgSpeedBinID	avgBinSpeed	avgSpeedBinDesc	6:00AM-9:00AM	3:00PM-6:00PM	9:01AM-2:59PM/6:01PM-5:59AM
1	2.5	speed < 2.5mph	9.94%	9.10%	7.92%
2	5	2.5mph <= speed < 7.5mph	13.79%	18.95%	14.49%
3	10	7.5mph <= speed < 12.5mph	34.07%	37.86%	31.36%
4	15	12.5mph <= speed < 17.5mph	28.52%	23.97%	29.17%
5	20	17.5mph <= speed < 22.5mph	10.02%	5.92%	10.77%
6	25	22.5mph <= speed < 27.5mph	1.88%	1.84%	3.91%
7	30	27.5mph <= speed < 32.5mph	0.92%	0.85%	1.04%
8	35	32.5mph <= speed < 37.5mph	0.34%	0.60%	0.72%
9	40	37.5mph <= speed < 42.5mph	0.14%	0.50%	0.35%
10	45	42.5mph <= speed < 47.5mph	0.05%	0.15%	0.15%
11	50	47.5mph <= speed < 52.5mph	0.31%	0.28%	0.06%
12	55	52.5mph <= speed < 57.5mph	0.00%	0.00%	0.06%
13	60	57.5mph <= speed < 62.5mph	0.00%	0.00%	0.00%
14	65	62.5mph <= speed < 67.5mph	0.00%	0.00%	0.00%
15	70	67.5mph <= speed < 72.5mph	0.00%	0.00%	0.00%
16	75	72.5mph <= speed	0.00%	0.00%	0.00%

Source: Fairfax County, VA

**Table 7 VHT Distribution of Transit Buses**

Speed Bins	Speed Range	Bus Trip 1	Bus Trip 2	Bus Trip 3	Bus Trip 4	Bus Trip 5	Bus Trip 6	Bus Trip 7	Bus Trip 8	Bus Trip 9	Bus Trip 10	Bus Trip 11	Weighted Average
1	speed < 2.5mph	35.20%	24.30%	17.58%	14.65%	7.90%	16.11%	6.65%	18.30%	25.76%	16.18%	17.67%	19.21%
2	2.5mph <= speed < 7.5mph	10.87%	11.57%	6.45%	11.04%	29.89%	20.20%	44.83%	11.01%	9.68%	6.49%	9.12%	14.39%
3	7.5mph <= speed < 12.5mph	10.90%	9.35%	12.89%	6.50%	26.31%	17.69%	3.34%	9.12%	9.52%	6.69%	8.69%	10.92%
4	12.5mph <= speed < 17.5mph	8.81%	9.18%	8.59%	9.45%	6.00%	11.13%	23.76%	10.12%	9.98%	8.46%	10.32%	10.37%
5	17.5mph <= speed < 22.5mph	5.01%	10.15%	5.18%	14.04%	3.04%	5.94%	4.09%	10.36%	7.57%	9.74%	12.02%	8.30%
6	22.5mph <= speed < 27.5mph	8.91%	8.55%	11.62%	12.59%	6.18%	5.30%	3.54%	7.29%	7.11%	8.87%	11.73%	8.13%
7	27.5mph <= speed < 32.5mph	8.79%	7.97%	14.36%	11.28%	5.86%	13.33%	6.35%	9.43%	5.37%	10.06%	10.20%	9.41%
8	32.5mph <= speed < 37.5mph	5.33%	9.10%	5.86%	13.43%	7.62%	3.32%	6.36%	13.79%	8.68%	12.04%	6.81%	7.81%
9	37.5mph <= speed < 42.5mph	3.43%	6.89%	8.69%	7.02%	4.80%	3.76%	1.07%	7.94%	9.79%	13.81%	8.16%	7.22%
10	42.5mph <= speed < 47.5mph	1.72%	2.44%	8.79%	0.00%	2.40%	2.87%	0.00%	1.31%	5.83%	5.15%	4.75%	3.42%
11	47.5mph <= speed < 52.5mph	0.68%	0.00%	0.00%	0.00%	0.00%	0.36%	0.00%	0.67%	0.31%	2.27%	0.36%	0.59%
12	52.5mph <= speed < 57.5mph	0.34%	0.50%	0.00%	0.00%	0.00%	0.00%	0.00%	0.67%	0.41%	0.24%	0.18%	0.23%
13	57.5mph <= speed < 62.5mph	0.00%	0.00%	0.00%	0.00%	0.00%	0.00%	0.00%	0.00%	0.00%	0.00%	0.00%	0.00%
14	62.5mph <= speed < 67.5mph	0.00%	0.00%	0.00%	0.00%	0.00%	0.00%	0.00%	0.00%	0.00%	0.00%	0.00%	0.00%
15	67.5mph <= speed < 72.5mph	0.00%	0.00%	0.00%	0.00%	0.00%	0.00%	0.00%	0.00%	0.00%	0.00%	0.00%	0.00%
16	72.5mph <= speed	0.00%	0.00%	0.00%	0.00%	0.00%	0.00%	0.00%	0.00%	0.00%	0.00%	0.00%	0.00%

Source: Washington Metropolitan Area Transit Authority (WMATA)

### 5.4 Road Type

COG/TPB travel demand model has six facility types; and these facilities are grouped into two as follows for MOVES:

- Restricted facility = freeway + expressway + freeway ramp; and
- Unrestricted facility = major arterial + minor arterial + collector.

Restricted and Unrestricted facilities are further divided into urban or rural facilities. Thus five facility types were created as urban restricted, urban unrestricted, rural restricted, rural unrestricted, and off network.

## 5.5 Age Distribution

Every three years since 2005, the departments of motor vehicles of the District of Columbia, Maryland, and Virginia have been supplying COG/TPB with vehicle registration data for use in Air Quality Conformity (AQC) Determinations and State Implementation Plan (SIP) updates. The most recent 2016 Vehicle Identification Number (VIN) data are a snapshot of vehicle registrations by year, collected by departments of motor vehicles in the three states. The VIN data contain a broad range of attributes of the vehicles registered in the jurisdictions of the Metropolitan Washington DC area. The latest data were used in the development of the vehicle population profiles (i.e., vehicle age and vehicle type distribution) for the 2015 Ozone NAAQS 2017 base-year emissions estimates.

Prior to using the VIN data as input to MOVES, the 'raw' vehicle registration data were decoded using a commercial decoding software program.<sup>9</sup> Following EPA's guidelines, the data were decoded in two steps: (1) the 'raw' data were decoded to a Mobile 6.2 format; and (2) the Mobile 6.2 format vehicle population distributions were converted to a MOVES format using an EPA converter.<sup>10</sup> Thus, 16 Mobile vehicle types and 25 vehicle age categories were mapped into MOVES' 13 vehicle and 31 vehicle age categories. The vehicle population of the 2016 VIN data was reviewed by the COG/TPB technical oversight committees prior to becoming approved for transportation planning applications.

## 5.6 Fuel Formulation

The state air agencies of the District of Columbia, the state of Maryland, and the Commonwealth of Virginia provided fuel characteristics data in a MOVES2014b ready format. For year 2017, the gasoline sulfur content was 25 ppm or lower.

## 5.7 Meteorology Data

The temperature and humidity data used for the 2015 Ozone NAAQS 2017 base year were developed using July 2017 meteorology data from Dulles International Airport.

## 5.8 Ramp Fraction

Local data were used to estimate the local ramp fraction using a method approved by the MOVES Task Force. The locally-derived percentage is equal to 8 percent of VHT, which, coincidentally, is the same as the MOVES default value.

## 5.9 Road Type Distribution

Vehicle Miles Traveled (VMT) was distributed into MOVES 13 vehicle types and four road (facility) types. The method of developing VMT distribution was as follows:

---

<sup>9</sup> VinPower, Copyright; ESP Data Solutions Inc., Product version 4.0.0.16

<sup>10</sup> RegistrationDistributionConverter\_Veh16

- Through post-processing of travel demand results, jurisdictional VMT distributions of six vehicle types were reclassified to VMT distributions by three vehicle types as follows:
  - Passenger Vehicles = SOV + HOV2 + HOV3 (or more) + Airport Passenger Trips;
  - Commercial Vehicles = Commercial Vehicles;
  - Heavy Duty Vehicles = Trucks.
- VMT percentages by three vehicle types were allocated to MOVES vehicle types as follows:
  - Passenger Vehicles: VMT percentages by facility type were applied to motorcycles, passenger cars and passenger trucks;
  - Commercial Vehicles: VMT percentages by facility type were applied to commercial trucks;
  - Heavy Duty Vehicles: VMT percentages by facility type were applied to single-unit short- and long-haul trucks, and combination short- and long-haul trucks;
  - Refuse Trucks and Motor Homes: MOVES default percentage values;
  - School, Transit and Intercity Buses (Tables 6 and 7): Local network percentages from local data sources (i.e., local bus operators); and
  - Urban and rural percentage split factors were used to further allocate facility type VMT between urban and rural facilities. These factors vary by jurisdiction and were based on the latest HPMS VMT data provided by the three state transportation agencies. Figure 4 illustrates the process of allocating VMT by vehicle type, facility type, and urban/rural split.

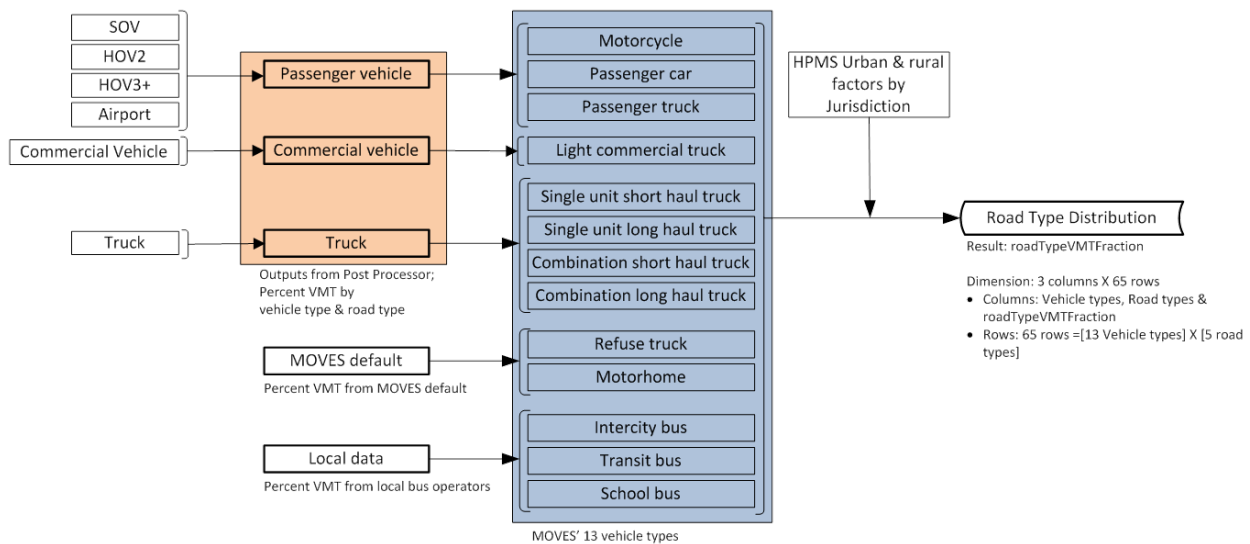

**Figure 4 Road Type Distribution Development Process**

### 5.10 Source Type (Vehicle) Population

Source type population, or vehicle population, was acquired from the vehicle registration (VIN) data. The VIN decoding software output vehicle population totals by Mobile 6.2 vehicle types. The vehicle population from the VIN data was then used to estimate vehicle population for 2017.

Table 8 shows the vehicle population for base year 2017. Vehicle profiles were prepared in a Mobile format in this data processing first and were converted to a MOVES vehicle type using a vehicle mapping table provided by EPA.

**Table 8 2017 Vehicle Population**

State	Jurisdiction	Vehicle Population
DC	District of Columbia	308,999
	<b>DC Total</b>	<b>308,999</b>
MD	Calvert County	91,525
	Charles County	140,213
	Frederick County	229,948
	Montgomery County	776,463
	Prince George's County	643,527
	<b>MD Total</b>	<b>1,881,676</b>
VA	City of Alexandria	130,271
	Arlington County	149,793
	Fairfax County	972,911
	Loudoun County	294,109
	Prince William County	414,079
	<b>VA total</b>	<b>1,961,164</b>
<b>Regional Total</b>		<b>4,151,840</b>

### 5.11 Inspection/Maintenance (I/M) Programs & Hoteling

The state air agencies of the District of Columbia, Maryland, and Virginia provided details of Inspection/Maintenance (I/M) programs in a MOVES2014b-ready format. Hotelling (or hoteling) is the term used in MOVES to refer to lengthy periods of idling by long-haul trucks, such as when truckers spend the night in their vehicles.<sup>11</sup> Hotelling data are not provided by local air agencies, so the MOVES default hoteling data were used.

### 5.12 Source Type (Vehicle) Population

In addition to the environmental inputs there are state-specific programs that were taken into account in the analyses:

- Early implementation of the National Low-Emission Vehicle (NLEV) Program: The District of Columbia, Maryland, and Virginia adopted an Early NLEV program, which was reflected. Early NLEV input database file – MOVES2014\_early\_NLEV
- Stage II Gasoline Vapor Control Programs: Varies by jurisdiction as follows:

<sup>11</sup> David Brzezinski, "Updating Hotelling Hours in MOVES," (December 7, 2016), <https://www.epa.gov/sites/production/files/2017-01/documents/hoteling-hrs-moves.pdf>.

- District of Columbia: MOVES2014b defaults
- Maryland: 1999 onwards - Refueling vapor program adjustment- 0.0, Refueling spill program adjustment- 0.0 for all years; MOVES2014b Stage II database file - md\_no\_stageii provided by MDE on 05.08.2019 through DEP
- Virginia: Refueling vapor program adjustment- .77 for years 1999-2010, .56 for years 2011-2013, and 0 for all other years; Refueling spill program adjustment- .77 for years 1999-2010, .56 for years 2011-2013, and 0 for all other years, MOVES2014b Stage II database file - va\_stage2\_input\_20161104 (provided by VDEQ on 05.08.2019)
- California's Low-Emission Vehicle (LEV)/Zero-Emission Vehicle (ZEV) Programs: Maryland's CAL-LEV program, adopted in 2011, is reflected in all analysis years. The following auxiliary files, provided by the Maryland Department of the Environment (MDE), were used to model these programs in the Maryland jurisdictions: ZEV\_AVFT\_MD\_moves2014b. It includes MOVES2014b ZEV Program Information for all MD MS-Excel input files as a tab.

## 6. RESULTS

On-road mobile inventories for the entire Ozone Non-Attainment area are shown in Tables 9, 10, and 11. Table 9 provides the total inventory for each pollutant while Table 10 shows the inventories by jurisdiction. Table 11 lists refueling emissions which are not part of on-road emissions but are reported for informational purposes. The inventories were produced using MOVES2014b, which reflects federal fuel and vehicle technology (Tier 3) programs.

**Table 9 On-Road Mobile Emissions Inventories (in short tons/day)**

Pollutant	2015 Ozone NAAQS
Volatile Organic Compounds (VOC)	49.564
Nitrogen Oxides (NOx)	93.413
Carbon Monoxide (CO)	673.213

\*For 8-Hour ozone non-attainment area

**Table 10 On-Road Mobile Emissions Inventories by Jurisdiction (in short tons/day)**

State	Jurisdiction	VOC	NOX	CO
DC	District of Columbia	3.761	5.634	54.936
	<b>DC Total</b>	<b>3.761</b>	<b>5.634</b>	<b>54.936</b>
MD	Calvert County	1.278	1.812	11.696
	Charles County	1.950	3.438	19.054
	Frederick County	3.814	9.981	53.149
	Montgomery County	8.969	15.777	119.587
	Prince George's County	9.360	20.278	135.401
	<b>MD Total</b>	<b>25.371</b>	<b>51.285</b>	<b>338.887</b>
VA	City of Alexandria	1.175	1.396	13.073
	Arlington County	1.505	1.916	21.973
	Fairfax County	10.109	18.411	145.371
	Loudoun County	3.096	6.324	41.279
	Prince William County	4.548	8.446	57.694
	<b>VA total</b>	<b>20.433</b>	<b>36.493</b>	<b>279.390</b>
<b>Regional Total</b>		<b>49.564</b>	<b>93.413</b>	<b>673.213</b>

\*For 8-Hour ozone non-attainment area

**Table 11 Refueling Emissions for 2015 Ozone NAAQS (in short tons/day)**

Refueling Emissions	2015 Ozone NAAQS
Refueling Spillage Loss	1.557
Refueling Displacement Vapor Loss	2.999

\*For 8-Hour ozone non-attainment area

A detailed listing of MOVES inputs, outputs, and configuration files is provided in Attachment C.

# ATTACHMENT A





## Non-travel Related MOVES Inputs (email dated May 18, 2019)



Sunil Kumar | Jinchul Park; Dusan Vuksan; Jane Posey; Mark Moran; Stephen Walz; Jennifer Desimone ▾

### Proposed Base Year 2017 Emissions Inventory (2015 Ozone NAAQS)

 You forwarded this message on 7/9/2019 11:44 AM.  
This message was sent with High importance.

---

**Action Items**

Please find the MS-Excel files containing MOVES2014b inputs for fuel supply, fuel usage fraction, fuel formulation, meteorology, and I/M programs for the proposed base year 2017 analysis for the 2015 ozone NAAQS.

The above input files have been placed in the folder – H:\SIP On-Road Emiss Inv\2015 Ozone SIP

Please use the three control programs listed below for 2017. Databases provided by states for modeling Early NLEV, Stage II, and Cal-Lev/ZEV programs are mentioned below.

Early NLEV Program  
Use early NLEV database titled "MOVES2014\_early\_NLEV" for DC, MD, and VA for all MOVES2014b runs.

Stage II  
DC: MOVES2014b defaults  
MD: MOVES2014b database (md\_no\_stageii)  
VA: MOVES2014b database (va\_stage2\_input\_20161104)  
Note: MDE first provided Stage II inputs (valid for the year 2017 and beyond) on 02.20.2018 to reflect removal of Stage II program in Maryland effective October 1, 2016.  
VDEQ first provided updated Stage II inputs (valid for 2014 and beyond) on 11.04.2016 to reflect removal of Stage II program in Virginia.

Cal-Lev Program (MD Only)  
MOVES2014b Cal-Lev database (MOVES2014\_caleviii2011)  
MOVES2014b ZEV Program info- is included in all MD Excel input files as a tab (ZEV\_AVFT\_MD\_moves2014b)  
Note: Maryland's Cal-Lev program is valid for the year 2011 and beyond.

Meteorology  
A new set of meteorology inputs was developed using data from the Dulles airport (IAD) for July 2017 in the MOVES2014b format by the COG/DEP staff for this analysis.

Please use the following combination of "representative month/week of the day" for the MOVES2014b runs.

Ozone season day – July/weekday

Thanks,

Sunil



# ATTACHMENT B



**MOVES TASK FORCE**  
**Summary of Local Data Development for the County Data Manager (Emissions Inventory Approach)\***  
**as of January 11, 2011**

LOCAL INPUT DATA CATEGORIES		DATA DESCRIPTION	DATA FORMAT	DATA DEVELOPMENT	LOCAL INPUT DATA APPROVAL DATE
			MOVES	METHODOLOGY	
1	<b>Age Distribution</b>	Registered vehicles stratified by age and vehicle type	31 Age Groups (covering 0-30+ years of vehicle age) 13 Vehicle Types	DTP used an EPA Converter to convert local registration data from MOBILE6.2 format to MOVES format	4/20/2010
2	<b>Average Speed Distribution</b>	Average vehicle speeds stratified by vehicle type, road type, time of day/type of day (i.e., weekday vs weekend)	Distributions of hourly average vehicle speeds by vehicle type, road type, and type of day (weekday/weekend)	DTP used MOBILE6.2 post-processor speed distribution augmented by local input data for school and transit buses and refuse trucks	Local VHT 7/20/2010 School Buses 9/21/2010 Refuse Trucks 9/21/2010 Transit Buses 10/19/2010
3	<b>Fuel Supply</b>	Market share of available fuels by county, month, year, state	MD/VA - EPA Methodology/local data in MOVES format DC - EPA Default Values	None Required (Direct Data Input from DC, MD, and VA air agencies)	Not Required
4	<b>Fuel Formulation</b>	Fuel formulation data stratified by state			
5	<b>I/M Programs</b>	Available Inspection/Maintenance Programs stratified by state			
6	<b>Meteorology Data</b>	Hourly temperature and relative humidity readings	Hourly Records of temperature and relative humidity in MOVES format Start Time: 12:00 am End Time: 11:00 pm	For Conformity Determinations - DEP converted meteorology data from existing SIPs to MOVES format using an EPA converter  For Upcoming SIP Development - DEP compiled meteorology datasets from two weather stations based on a 3-yr period (2007-09) pending EPA approval	06/22/2010 (SIP for 2008 or Later Ozone Standard)  07/20/2010 (Conformity for Ozone & PM2.5 – 1997 Standards, CO – 1971 Standard)
7	<b>Ramp Fraction</b>	Percentage of driving time on ramps stratified by road type	8% of VHT (EPA National Default )	DTP tested local input data and found consistent with the EPA National Default value	7/20/2010
8	<b>Road Type Distribution</b>	Percentages of VMT allocated to each road type by vehicle type	VMT percentages by road type and vehicle type	DTP combined VMT from the travel demand model; and VMT distributions from the travel demand model, NEI data, and MOVES default data	4/20/2010
9	<b>Source Type Population</b>	Population of registered vehicles by county and vehicle type	13 Vehicle Types	DTP used vehicle registration and source type fractions	
10	<b>Vehicle Type VMT</b>	Annual VMT by HPMS vehicle type	Annual VMT allocated by HPMS vehicle type	DTP used daily VMT and an EPA converter	4/20/2010

\* The Task Force adopted the Emissions Inventory Approach (October 19, 2010)

\*\* Documents can be found on the MOVES Task Force [http://www.mwcog.org/committee/committee/documents.asp?COMMITTEE\\_ID=253](http://www.mwcog.org/committee/committee/documents.asp?COMMITTEE_ID=253)

MOVES TASK FORCE			
Summary of MOVES Data Development Documentation			
as of January 11, 2011			
LOCAL INPUT DATA CATEGORIES	DATA DESCRIPTION	DATA DOCUMENTATION	
		METHODOLOGY	SENSITIVITY TESTING
1	Age Distribution	Registered vehicles stratified by age and vehicle type	<p>Memorandum titled "Development of Local Transportation Data Inputs for MOVES2010 Model" D. Sivasailam            Memorandum Drafted: 4/13/2010            Memorandum Presented: 4/20/2010 (Item 3)            Memorandum Revised: 5/14/2010 (Item 3b)</p> <p>Memorandum titled "Results of MOVES 2010 Model Sensitivity...", E. Lucas, Drafted/presented 4/20/2010 (Item 4)            Memorandum titled "Results of MOVES2010 Model Sensitivity...", E. Lucas, Drafted/presented 5/18/2010 (Item 4a)</p>
2	Average Speed Distribution	Average vehicle speeds stratified by vehicle type, road type, time of day/type of day (i.e., weekday vs weekend)	<p>Memorandum titled "Local Vehicle Hours of Travel (VHT) Distributions," D. Sivasailam Drafted/presented 7/20/10 (Item 3b)</p> <p>Tables titled "School Bus Average Speed Distribution," Drafted/presented 9/21/2010 (Item 3a)</p> <p>Memorandum titled "Vehicle Hours of Travel (VHT) for Refuse Trucks," D. Sivasailam and E. Morrow, Drafted/presented on 9/21/2010 (Item 3a)</p> <p>Memorandum titled "MOVES Vehicle Hours of Travel (VHT) Distribution for Transit Buses," Y. Gao" Drafted/presented on 10/19/2010 (Item 3)</p> <p>Memorandum titled "Results of MOVES2010 Model Sensitivity Tests: Final Scenario for Average Speed Testing," E. Lucas Memorandum Drafted: 10/16/2010            Memorandum Presented: 10/19/2010 (Item 4)</p> <p>Memorandum titled "Proposed Sensitivity Tests with Different Average Speed Distributions/SIP Temperatures" Drafted/presented 9/21/2010 (Item 3a)</p>
3	Fuel Supply	Market share of available fuels by county, month, year, state	<p>Memorandum titled "Results of MOVES2010 Model Sensitivity Tests:...Maryland Clean Car Program-ZEV," E. Lucas, Drafted/presented 5/18/2010 (Item 4a)</p> <p>Memorandum titled "Results of MOVES2010 Model Sensitivity Tests:...Maryland Clean Car Program-ZEV," E. Lucas, Drafted/presented 5/18/2010 (Item 4a)</p>
4	Fuel Formulation	Fuel formulation data stratified by state	
5	I/M Programs	Available Inspection/Maintenance Programs stratified by state	
6	Meteorology Data	Hourly temperature and relative humidity readings	<p>Memorandum titled "Development of Methodologies for Meteorology, I/M Program, and Fuel Inputs for Upcoming Ozone SIP (2008 or 2010 Standard) and Existing Conformity Analyses (Ozone &amp; PM2.5 - 1997 Standards, CO - 1971 Standard)," S. Kumar Drafted/presented 6/22/2010 (Item 4a)</p> <p>Memorandum titled "Development of Meteorology Inputs for existing Conformity Analyses (Ozone &amp; PM2.5 - 1997 Standards, CO - 1971 Standard)," S. Kumar Drafted/presented 7/20/2010 (Item3a)"</p> <p>Memorandum titled "Results of MOVES2010 Model Sensitivity Tests:...Maryland Clean Car Program-ZEV," E. Lucas, Drafted/presented 5/18/2010 (Item 4a)</p>
7	Ramp Fraction	Percentage of driving time on ramps stratified by road type	<p>Memorandum titled "Results of MOVES 2010 Model Ramp Analysis," E. Lucas, Drafted/presented 7/20/2010 (Item 4a)</p> <p>Memorandum titled "Results of MOVES 2010 Model Ramp Analysis," E. Lucas, Drafted/presented 7/20/2010 (Item 4a)</p>
8	Road Type Distribution	Percentages of VMT allocated to each road type by vehicle type	<p>Memorandum titled "Results of MOVES 2010 Model Sensitivity...", E. Lucas, Drafted/presented 4/20/2010 (Item 4)            Memorandum titled "Results of MOVES2010 Model Sensitivity...", E. Lucas, Drafted/presented 5/18/2010 (Item 4a)</p>
9	Source Type Population	Population of registered vehicles by county and vehicle type	
10	Vehicle Type VMT	Annual VMT by HPMS vehicle type	<p>Memorandum titled "Development of Annual VMT for MOVES2010."D. Sivasailam            Memorandum Drafted: 4/16/2010            Memorandum Presented: 4/20/2010 (Item 3)            Memorandum Revised: 5/14/2010 (Item 3b)</p> <p>Memorandum titled "Results of MOVES 2010 Model Sensitivity...", E. Lucas, Drafted/presented 4/20/2010 (Item 4)            Memorandum titled "Results of MOVES2010 Model Sensitivity...", E. Lucas, Drafted/presented 5/18/2010 (Item 4a)</p>

# ATTACHMENT C





## Input, Output, and “Runspec” MOVES2014b Files for 2017

### Year 2017

Input	Output	Runspec
OZN_DC_2017_NAAQ_In	OZN_DC_2017_NAAQ_Out	OZN_DC_2017_NAAQ.MRS
OZN_NoAVFT_CAL_2017_NAAQ_In	OZN_NoAVFT_CAL_2017_NAAQ_Out	OZN_NoAVFT_CAL_2017_NAAQ.MRS
OZN_AVFT_CAL_2017_NAAQ_In	OZN_AVFT_CAL_2017_NAAQ_Out	OZN_AVFT_CAL_2017_NAAQ.MRS
OZN_NoAVFT_CHL_2017_NAAQ_In	OZN_NoAVFT_CHL_2017_NAAQ_Out	OZN_NoAVFT_CHL_2017_NAAQ.MRS
OZN_AVFT_CHL_2017_NAAQ_In	OZN_AVFT_CHL_2017_NAAQ_Out	OZN_AVFT_CHL_2017_NAAQ.MRS
OZN_NoAVFT_FRD_2017_NAAQ_In	OZN_NoAVFT_FRD_2017_NAAQ_Out	OZN_NoAVFT_FRD_2017_NAAQ.MRS
OZN_AVFT_FRD_2017_NAAQ_In	OZN_AVFT_FRD_2017_NAAQ_Out	OZN_AVFT_FRD_2017_NAAQ.MRS
OZN_NoAVFT_MTG_2017_NAAQ_In	OZN_NoAVFT_MTG_2017_NAAQ_Out	OZN_NoAVFT_MTG_2017_NAAQ.MRS
OZN_AVFT_MTG_2017_NAAQ_In	OZN_AVFT_MTG_2017_NAAQ_Out	OZN_AVFT_MTG_2017_NAAQ.MRS
OZN_NoAVFT_PG_2017_NAAQ_In	OZN_NoAVFT_PG_2017_NAAQ_Out	OZN_NoAVFT_PG_2017_NAAQ.MRS
OZN_AVFT_PG_2017_NAAQ_In	OZN_AVFT_PG_2017_NAAQ_Out	OZN_AVFT_PG_2017_NAAQ.MRS
OZN_FFX_2017_NAAQ_In	OZN_FFX_2017_NAAQ_Out	OZN_FFX_2017_NAAQ.MRS
OZN_LDN_2017_NAAQ_In	OZN_LDN_2017_NAAQ_Out	OZN_LDN_2017_NAAQ.MRS
OZN_PW_2017_NAAQ_In	OZN_PW_2017_NAAQ_Out	OZN_PW_2017_NAAQ.MRS